



OWNERS MANUAL

MODEL: US-MBA-B14

DESCRIPTION: BEAM ANCHOR ALUMINUM 14"

MEETS OSHA & ANSI Z359.1

1-800-850-5914

PHOENIX, ARIZONA USA

WWW.ULTRASAFEUSA.COM

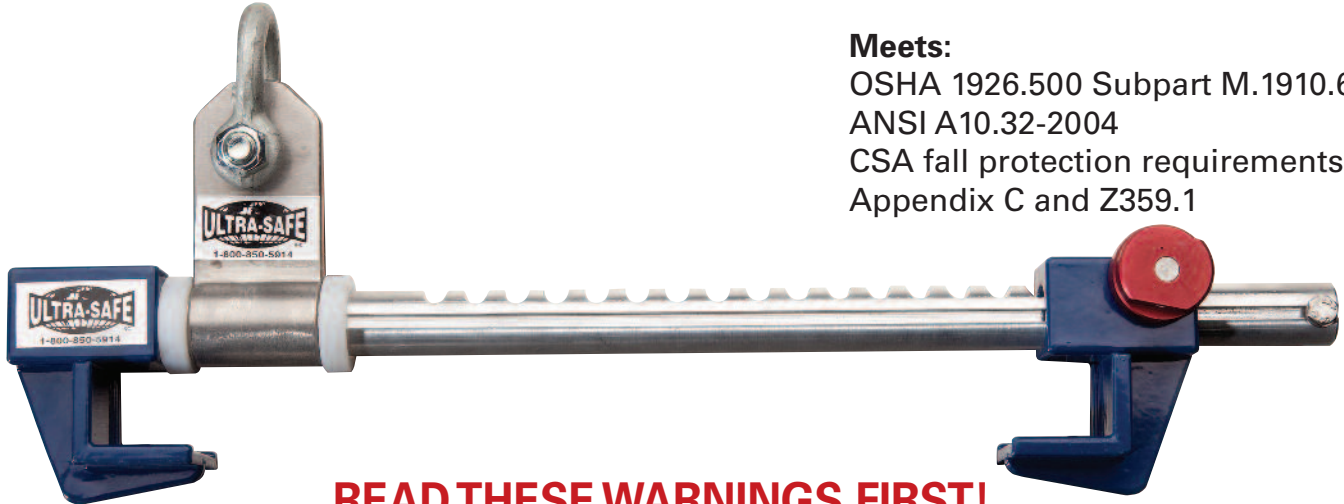

Meets:

OSHA 1926.500 Subpart M.1910.66

ANSI A10.32-2004

CSA fall protection requirements

Appendix C and Z359.1

READ THESE WARNINGS FIRST!

The Sliding Beam Anchor is only part of a total fall protection system and the use of compatible hardware and components is mandatory. The system components must meet federal, state, local or provincial regulations before being incorporated in a personal fall protection system. It is imperative for the safety and efficiency of operations that this manual be read and fully understood by the worker before using any fall arrest system. ALL instructions contained herein must be carefully read and strictly followed for proper use and maintenance of the equipment. Alterations or misuse of this product, or failure to follow instructions may result in serious injury or death. If you have any questions, please contact your distributor or Ultra-Safe, Inc.

- Always calculate the fall distance and ensure that a clear, unobstructed distance is provided under the beam to which the worker is attached. Remember to allow for system elongation and safety margin.
- Units subjected to fall arrest forces shall be immediately removed from service and not use again until the Sliding Beam Anchor is inspected by a qualified person.
- Make sure that all the components are compatible and that the potential impact forces, free fall distances, and deceleration distances are within the allowances of applicable regulations.

- Ensure that the structural element to which the worker is attached is capable of sustaining fall arrest forces of 5,400 lbs. (24kN) or twice the potential impact when designed installed and used under the supervision of a qualified person. Do not tie off the structural beam that is less than 8 in. deep.
- One worker only. Never attach more than one worker to the Sliding Beam Anchor.
- Attach this device at or above the connection point on your harness whenever possible to minimize the free fall distance. If this device is connected below the attachment point, you must ensure that the system is designed for this type of attachment, can withstand that potential impact forces and can absorb a sufficient amount of fall arrest force.
- The Sliding Beam Anchor is designed for attachment to a structural beam only. Do not use on open web steel hoists.
- A qualified person shall inspect the beam anchor at regular intervals. Units that do not pass inspection shall be immediately returned to Ultra-Safe, Inc. for repair. Satisfactory inspections should be marked on the provided inspection log.



IN AN ENVIRONMENT WHERE A FALL HAZARD EXISTS, SAFETY IS A MATTER OF LIFE OR DEATH FOR WORKERS AND BYSTANDERS. THIS WARNING IS YOUR SHARE OF DUTIES FOR ACHIEVING SAFETY.

1. YOUR DUTY TO UNDERSTAND AND COMPLY

- 1.1 It is the worker's and their employers responsibility to strictly conform to the following warnings.
- 1.2 Under whatever conditions, should you hand over any components of a fall arrest system to a party operating out of your control, you must provide a clean copy of this guide and draw the other party's attention that strictly following all the instructions therein is a matter of life or death.
- 1.3 Before using any fall arrest system, the worker and employer must become aware of all requirements of federal, state, local and provincial safety regulations applicable to the use of the fall arrest system and any component thereof. Components of a fall arrest system must be compatible and recommended by Ultra-Safe, Inc.
- 1.4 Never use a fall arrest system or any components for any applications other than specified by the instructions supplied by the manufacturer of that device. Do not alter or adapt the equipment in any way.
- 1.5 Any harness, lanyard, rope grab, self-retracting lifelines or hardware which has been subjected to fall-arrest, must be removed immediately from service. The harness, lanyard, rope grab, or hardware must be destroyed and replaced. The Sliding Beam Anchor must be sent to Ultra-Safe, Inc.
- 1.6 The combination of the user's weight, clothing and tools may not exceed 310 lbs. (140 kg). If this weight is exceeded the performance and safety of a Sliding Beam Anchor cannot be guaranteed.

- 1.7 This manual is intended to meet the standards as required by ANSI Z359.1 and should be used as part of an employee-training program as required by OSHA.

2. YOUR DUTY TO UNDERSTAND AND MAINTAIN

- 2.1 Keep this guide available at all the times for easy reference whenever required. Extra copies are available from Ultra-Safe, Inc.
- 2.2 Carefully take notice of all labels affixed to all components of the fall arrest system. Never use any equipment if the label normally fixed on fall arrest components obscure or missing. Ultra-Safe, Inc. will supply extra labels for Ultra-Safe, Inc. products at customer request.
- 2.3 Every time a fall arrest system is used, check prior to proceeding that components of the system are complete, compatible and in good working conditions.
- 2.4 Careful and regular inspection of the fall arrest system's installation is a part of the safety requirements. If you have any questions contact Ultra-Safe, Inc.

3. YOUR DUTY TO TRAIN AND CONTROL PEOPLE

- 3.1 Health conditions of the operator must be compatible with a possible fall arrest operations used. A worker must not be assigned to a job when a fall arrest system is required, if this worker is not:
 - a) mentally and physically fit for the purpose, especially at heights or in confined spaces;
 - b) free from the influence of alcohol or drugs;
 - c) competent for the job to be performed;
 - d) familiar with the equipment and all applicable safety rules, requirements or regulations;
 - e) trained for working under the above requirements. Training session must be performed under safe conditions.

- 3.2 Except for the operations described in this manual, the maintenance of Ultra-Safe, Inc. equipment as well as repair must be exclusively done by authorized (written approval) Ultra-Safe, Inc. dealers or by Ultra-Safe, Inc.
- 3.3 Never let a fall arrest system to be managed or use by anyone other than authorized and assign person to the job. While out of operation, keep system installed or stored out of reach of unauthorized person.
- 3.4 Training workers include setting up rescue procedure should a fall occur during a job prior to putting the system into operation. Such procedure must be set up by a qualified person or technical consultant according to work conditions.
- 3.5 Every job must be placed under the control of a person having the required qualifications and authority for checking that all the instructions prescribed by manual regularly and efficiently carried out. Contact Mechanical Safety Corp for training information.

4. YOUR DUTY BEYOND THE FALL ARREST SYSTEM

- 4.1 Components of the installation other than the Sliding Beam Anchor must meet the requirements of the applicable regulations and legislation. They must be of the specified quality and must be assembled as a safe and efficient fall arrest system.
- 4.2 Anchor points are to have minimal strength of 5,000 lbs. (22 kN), be sufficiently strong and accordance with federal, state, provincial and local regulations.
- 4.3 All requirements in strength and resistance must be obtained with the necessary safety coefficients.
- 4.4 Prior to commencing the job, all the calculations, the design and subsequent work necessary to the above requirements must be made by a qualified person on the basis of technical information regarding the site.

5. YOUR DUTY TO AVOID TAKING CHANCES

- 5.1 For any job to be performed, consider and control the specific risk related to the nature of the job.
- 5.2 After inspection, should you decide that a fall arrest system or any components no longer to be used, take precautions in disposing of it so that it cannot be reused. It has to be discarded or disposed. Precautions must be taken so it cannot be used.
- 5.3 During a rescue, the line or lines should be attached only to the single-mounted back D-ring and/or to both shoulder-mounted D-rings of the harness.

6. FUNCTION AND DESCRIPTION

6.1 Function

6.1 The Sliding Beam Anchor is a mobile anchor device designed for personal fall protection on structural beams.

6.2 Description

Description of the parts (see figure 1):

- 1. stationary jaw
- 2. shackle
- 3. extenuation plate
- 4. rollers
- 5. automatic locking mechanism
- 6. crossbar
- 7. mobile jaw

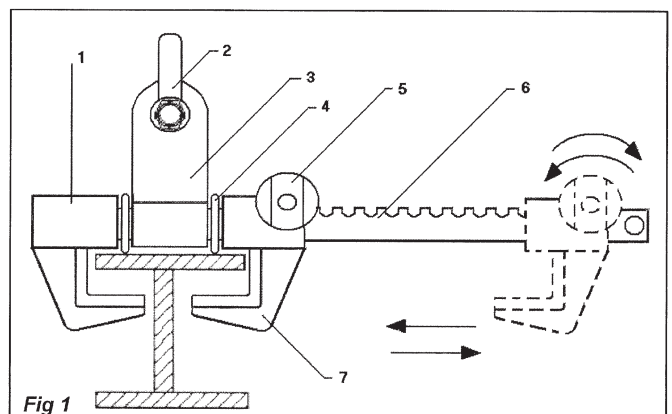

Fig 1

6.3 It is simple and quick to install and just as easily to remove and take to another site. It must be used with the back D-ring style full body harness and shock-absorbing lanyard as part of a complete fall protection system.

The Sliding Beam Anchor is a device supporting following features:

- 1) The presence of rollers allows the Sliding Beam Anchor to move freely along the beam flange.
- 2) The jaw automatically secures its position on the crossbar.
- 3) The anchor can be installed on the beam flange quickly and easily, and can be removed to be taken to another site.
- 4) The extenuation plate with the shackle provides a connection between the beam anchor and the shock absorber connected to the workers harness.

7. INSTALLATION

7.1 You can use the Sliding Beam Anchor to provide you freedom of movement, as the anchor effortlessly slides across the beam.

7.2 Anchoring to the structure

- a) Before use make sure that the Sliding Beam Anchor is fully compatible with the width of the beam flange 4 to 14 in (see figure 2 and 3, page 6).
- b) Fit the fixed jaw to the flange of the beam so the jaw is touching the beam tightly. Be sure that the first roller is on the surface of the beam (see figure 3, page 6)
- c) Twist the knob of the mobile jaw counterclockwise and slide it until it is touching the beam tightly. Be sure that the first roller is on the surface of the beam (see figure 4, page 6)
- d) Release the knob. If the pin on the knob is not engaged in the groove of the crossbar, push the crossbar along its axis until you hear a click, indicating that the pin is fixed in the groove.

- e) Test the Sliding Beam Anchor by manipulating on either direction to make sure that the beam anchor will not come off the beam. These tests should be performed in safe position.
- f) Once the sliding Beam Anchor is attached to the beam, connect one end of the shock-absorbing lanyard to the shackle and the other end to the D-ring of the full body harness.

7.3 Removal

To remove the Sliding Beam Anchor from the flange, perform the same steps in the opposite order.

MBA-A

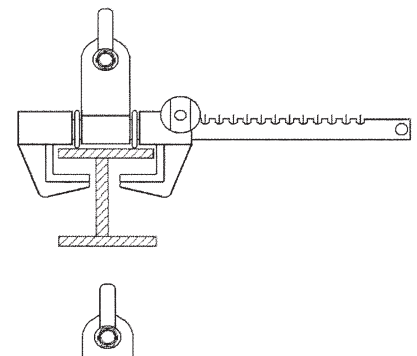

8. OPERATION

- 8.1 The user connects the shock-absorbing lanyard to his/her harness' back D-ring.
- 8.2 When working on a structure, use caution when along the beam. Paint build-up, welding spatter, scale, fasteners, or other obstructions on the beam could affect the Sliding Beam Anchor's ability to move freely along the beam. An obstruction could cause loss of balance. Be aware of hazards on your working area. Do not allow the connecting system (shock-absorbing lanyard) to pass under your arm or between your feet.

8.3 Beam joints

When passing from one beam to adjacent beam, ensure the sliding beam anchor remains secure. The maximum gap between adjacent beams must be limited to 1/2 in.

8.4 Use a beam that is capable of supporting the required loads, as selected by a qualified person. If the beam is sloped or vertical, the sliding beam clamp must be positioned next to a stop that will prevent the sliding beam clamp from moving in the event of a fall. In horizontal travel, the Sliding Beam Anchor can ride both top and bottom of the beam. (see figure 3).

8.5 Components that have been subjected to fall arrest force must be removed from service and destroyed.

- Elevation of the Sliding Beam Anchor
- Connection subsystem (shock-absorbing lanyard) length
- Deceleration distance, can elongate up to 42 in. (1.1 m)
- Movement of harness attachment element
- Worker height
- Free fall distance

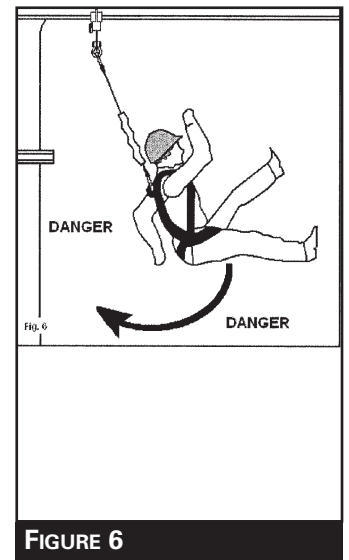
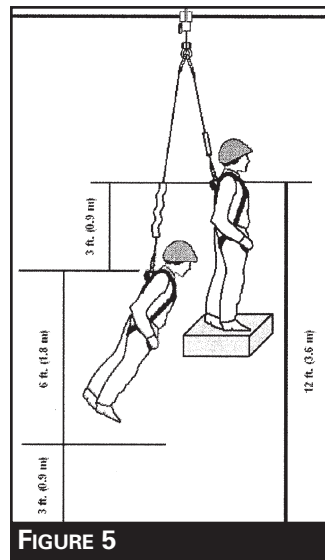

WARNING

The limit of one person only per fall arrest system must always be observed.

9. SYSTEM COMPONENT REQUIREMENT

9.1 Anchor system

An anchorage point is a secure point of attachment for lanyards or lifelines. It has to be independent of the means of supporting the worker and must be approved by qualified person. For fall arrest, the anchor point must support a minimum of 5,400 lbs. (24 kN) per attached worker. Consult governing regulations as revisions occur.

9.1.1 Every anchor point must be selected with care. The anchorage point location, in combination with the lanyard never permit a free fall of more than six (6) ft. (1.8 m) (see figure 5). Consult local governing regulations as allowable free fall distance varies. Always check for obstructions below the work area to make sure that potential fall path is clear. When selecting an anchorage point, there must be sufficient clearance below the user to arrest a fall before this user strikes the ground or other obstruction. The clearance required depends on the following factors:

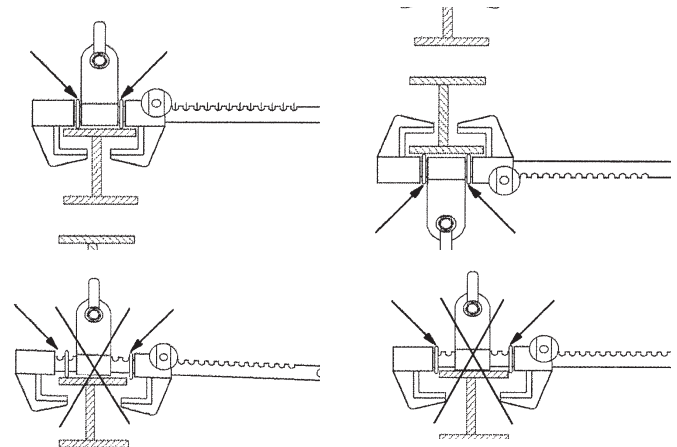

9.1.2 Always use directly under the anchorage point to avoid a swing fall. The force of striking an object in a swing fall may cause serious injury. Minimize swing falls by working as close to the anchorage point as possible (see figure 6).



9.1.3 Never use an anchor point, which does not allow the snap hook keeper to close. Anchor must be compatible with snap hook and must not be capable of causing a load to be applied to the snap keeper.

WARNING

Use with shock-absorbing lanyard only.

9.2 Lanyard

The impact forces developed during a fall are a combination of a free fall distance and the weight applied. Since the regulations impose that the impact forces do not exceed 1,800 lbs. (8kN), the length of the lanyard should be calculated accordingly. In order to avoid any complicated calculations and as a matter of precaution, it is recommended to use a lanyard with a maximum length of 3ft. (0.9 m). For fall arrest, a shock-absorbing lanyard must be used to ensure that the impact force does not exceed 1,800 lbs. (8 kN). Consult local governing regulations as allowable free fall distance varies.

9.3 Harness

For fall arrest purpose, the use of a full body harness is mandatory. Attach the lanyard to the back D-ring of the harness.

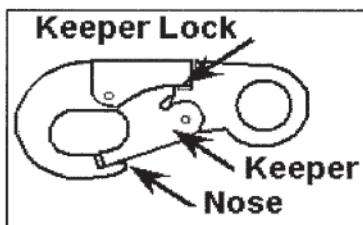

10. LIMITATIONS OF THE EQUIPMENT

10.1 One worker only. Never attach more than one worker to the Sliding Beam Anchor.

10.2 Capacity

The Sliding Beam Anchor has a 310 lbs. (140 kg) rated working capacity. User's weight, clothing and tools may not exceed 310 lbs. (140 kg).

10.3 Electrical hazards

Take extreme caution when working near or around high voltage power lines: electricity could pass through Sliding Beam Anchor or connecting devices resulting electrocution.

10.4 Sharp edges

Avoid working where the connecting subsystem (shock-absorbing lanyard) or other system components will be in contact with, or abrade against, unprotected sharp edges. If working around sharp edges is unavoidable, protection must be provided with a suitable protective cover.

10.5 Life

Every Sliding Beam Anchor that shows signs of wear, damage or degradation must be removed 12.1 from service and sent to Ultra-Safe, Inc. in order to be inspected and recertified by authorized person. For further details, refer to article 11 below.

WARNING

Bolts or rivets that are discolored, pitted or cracked indicate chemical corrosion.

11. INSPECTION

11.1 All equipment must be inspected visually before each use and periodically (at least once a year) by a qualified person. If damage is found as described below, immediately remove the item from services and replace it. If any damage or questionable conditions are apparent that are not described below, immediately remove item from service, replace it and contact Ultra-Safe, Inc.

11.2 Failure to remove equipment that has been damaged or has questionable condition could lead to serious or fatal injury. A detailed record of inspection should be maintained. See back page for suggested record sheet.



11.3 All parts should be inspected for rough or sharp edges., corrosion, burns, cracks, dents and distortion. Ensure no parts are missing (locking pins, fasteners, labels...). Inspect Sliding Beam Anchor for excessive corrosion. Inspect jaws to ensure they have not worn to a point where the hook ends will be in direct contact with the beam flange.

11.4 **Self-locking snap hook**
The keeper should sit in to the nose without binding and should not be distorted or obstructed. The spring should exert enough force to firmly close the keeper. The keeper lock must prevent the keeper from opening when closed (see figure 7).

11.5 For every other component, refer to appropriate inspection instructions.

WARNING

Any equipment that fails to meet the above inspection requirements shall be removed from service. Only Ultra-Safe, Inc., or persons or legal entities authorized in writing by Ultra-Safe, Inc., shall make repairs to Ultra-Safe, Inc.

12. LABELING

12.1 Read all the labels on the Sliding Beam Anchor. They must always be intact and easy to read. (see figure 8).

13. MAINTENANCE AND STORAGE

13.1 Failure to maintain and store equipment carefully can result in damage and malfunction that could lead to serious or fatal injury.

13.2 Maintenance and cleaning

Periodically clean the Sliding Beam Anchor using water and mild soap solution. Do not use acids or chemicals that could damage the system components. A lubricant can be applied to the locking mechanism.

FOR USE ONLY ON HORIZONTAL BEAM FLANGE

Turn knob 90° counterclockwise
& position sliding block tightly against beam. Push in back of bar until sliding block locks (click) into position

ULTRA-SAFE Beam Anchor

For use on Structural
Steel I-Beams

MODEL # _____

Read and understand instructions provided. This beam anchor is designed as fall protection for personnel while working at heights. To be used with appropriate lanyard and full body harness only. For use by properly trained individuals only. The suitability of this device for the intended purpose must be determined prior to use.

CARELESS OR IMPROPER USE OF THIS DEVICE MAY RESULT IN SERIOUS INJURY OR DEATH Inspect prior of each use. Worn or damaged equipment must be removed from service.

Units subjected to fall arresting forces shall be removed from service. If there are any questions as to the correct use of this product, contact:

**Ultra-Safe, Inc. 2339 N. 39th Drive
Phoenix, AZ 85009 - (602) 484-7713**

13.3 Storage

When the Sliding Beam Anchor is not in use it must be kept in a dry environment and sheltered from weather in order to prevent corrosion.

14. WARRANTY INFORMATION

14.1 Ultra-Safe, Inc. warrants its equipment to be free from defects of materials and workmanship under normal use and services.

14.2 Our obligation under this warranty limited to repairing or replacing, at our option, any part of the unit, which proves under examination to our satisfaction, to be defective in materials or workmanship. The item in question is to be returned to Ultra-Safe, Inc. upon authorization. Return shipment must be prepaid.



- 14.3 Any parts prove to be defective upon inspection by Ultra-Safe, Inc. will be repaired or replaced at no cost to the customer.
- 14.4 The obligation under this warranty does not include labor or transportation costs or ensuing damage of any kind.
- 14.5 Any defect in the equipment must immediately be brought to the attention of Ultra-Safe, Inc.
- 14.6 Ultra-Safe, Inc. obligations are restricted to replacing parts and does not include complete unit. The warranty is void on any unit that has been

modified or tempered with, repaired by person other than factory representative, repaired with other than Ultra-Safe, Inc. standard parts, or damaged by reasons of accident, alternation, misuse or abuse.

- 14.7 This warranty is in lieu of all other warranties, expressed or implied. We do no authorize any person or representative to make any other guarantee or to assume for us any liability in connection with the sale of our appliances other than those contained herein. Any agreement outside our contradictory the foregoing shall be void and of no effect.

Purchase Date:	Service Entry Date:	User's Name:
----------------	---------------------	--------------

Inspection Check List

DATE	INSPECTION NOTES	CORRECT ACTION TAKEN	INSPECTION PERFORMED BY	SIGNATURE
	PASS ○ FAIL ○	RETURN TO REPAIR ○ DESTROY ○		
	PASS ○ FAIL ○	RETURN TO REPAIR ○ DESTROY ○		
	PASS ○ FAIL ○	RETURN TO REPAIR ○ DESTROY ○		
	PASS ○ FAIL ○	RETURN TO REPAIR ○ DESTROY ○		
	PASS ○ FAIL ○	RETURN TO REPAIR ○ DESTROY ○		
	PASS ○ FAIL ○	RETURN TO REPAIR ○ DESTROY ○		
	PASS ○ FAIL ○	RETURN TO REPAIR ○ DESTROY ○		
	PASS ○ FAIL ○	RETURN TO REPAIR ○ DESTROY ○		

